



## ECHO M 215 WHITE DALI

Flexible luminaire with reflector technology and a high-positioned light source for very good anti-glare properties. All-round luminaire for public environments where more light is needed, e.g. rooms with high ceilings. For new installations or replacement of old compact fluorescent lamp fixtures for a much more energy-efficient installation. Adjustable lumen output and selectable colour temperature via DIP switch, 3000K, 4000K and 5700K. Complete with driver for phase dimming or DALI 2, with push-in terminals and screwless strain relief. Cover ring available as an accessory. Can be supplied with Q-Box Mini or Linect.

### DESCRIPTION

<b>GTIN:</b>	7392971148243
<b>Item Name:</b>	Echo M 215 White DALI
<b>Warranty:</b>	5 years

### LIGHT TECHNICAL DATA

<b>Max. Luminaire Lumen (lm):</b>	1870
<b>Light Source:</b>	LED
<b>Replaceability:</b>	Replaceable LED by professional, Replaceable Control gear by professional
<b>LED Colour:</b>	White
<b>Colour Temperature (K):</b>	3000, 4000, 5700
<b>Colour Rendering Index (Ra):</b>	>80
<b>Colour Consistency (SDCM):</b>	3
<b>Luminous Intensity (cd):</b>	1080
<b>Beam Angle (°):</b>	85
<b>Light sharing:</b>	Symmetric
<b>Light Outlet:</b>	Direct
<b>Number of Lamps (pcs):</b>	1
<b>Number of LED (pcs):</b>	120
<b>Life Time:</b>	h Ta °C
<b>Nominal Life Time (h):</b>	50000
<b>Lumen maintenance 50 000h:</b>	L80
<b>Lumen maintenance 75 000h:</b>	L71
<b>LLMF @ 50 000h:</b>	0.8
<b>Life Time Driver:</b>	50 000h/10%
<b>Flicker (PstLM):</b>	0,002
<b>Stroboscopic effect (SVM):</b>	0,007

## TECHNICAL DATA

Voltage (type):	AC
Voltage Interval (V):	220...240V
Voltage Nominal (V):	230
Line Frequency (Hz):	50, 60
Power LED (W):	16
Max. Power Luminaire (W):	20
Max. System Power (W):	20
Max. Efficiency Luminaire (lm/W):	93,5
Max. Efficiency System (lm/W):	93,5

Containing light source energy efficiency class (EU) 2019/2015: E

## OPERATION AND CONNECTION

Dimmable:	Yes
Type of Dimming:	DIP-Switch Power, Push 230V, 1-10V, DALI 2
Driver Included:	Yes
Driver Model:	Constant Current
Driver Type:	Stand Alone
Driver Manufacturer:	Hide-a-lite
Connection (type):	Quick Terminal
Connection (mm2):	5x0,5-1,5
Through Wiring:	Yes
Strain Relief:	Yes
Power Factor $\lambda$ :	0,9
Efficiency (%):	83
Power loss (W):	3,5
Leakage current (mA) (at 230 V, 50 Hz, full load):	0,5
Constant Current (mA):	250, 300, 350, 400, 450, 500
Min. Ta (°C):	-20
Max. Ta (°C):	40
Max. Tc (°C):	85
Dimming secondary side:	AM
Suitable for random switching:	Yes
Memory Function Power Failure:	Yes
Inrush current (max/time):	4,5A 90 $\mu$ s
Mains surge protection DM (kV):	1
Mains surge protection CM (kV):	2
Fuse B10 (pcs):	33
Fuse B16 (pcs):	52
Fuse C10 (pcs):	55
Fuse C16 (pcs):	88

## COLOR AND MATERIAL

Material:	Aluminium
Color:	White
Environmental Assessment:	Byggvarubedömningen
Available in special color:	Yes

## MEASUREMENT AND INSTALLATION

<b>Operating Environment:</b>	Indoor / wet locations, Outdoor
<b>IP Degree of Protection:</b>	44
<b>Protection Class:</b>	II
<b>Installation:</b>	Built-in
<b>Mounting Installation:</b>	Mounting Spring
<b>Ceiling Thickness Interval (mm):</b>	5-40mm
<b>Fire Safety Marks:</b>	Not in insulation without protection cover
<b>Approval Marks:</b>	CE, a Hide-a-lite Choice
<b>Filament Test IEC 695-2-1(°C):</b>	650
<b>Height (mm):</b>	106
<b>Diameter (mm):</b>	215
<b>Weight (kg):</b>	0,82
<b>Height Recessed Part (mm):</b>	102
<b>Height Exterior Part (mm):</b>	4
<b>Built-in Ø (mm):</b>	150-200mm

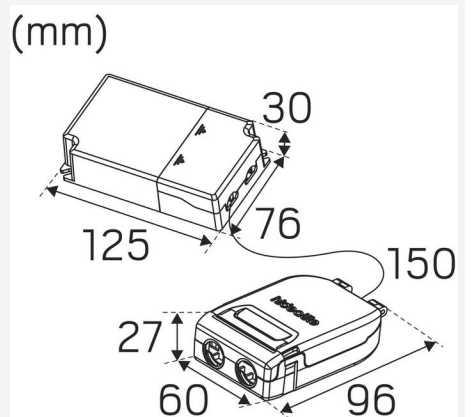
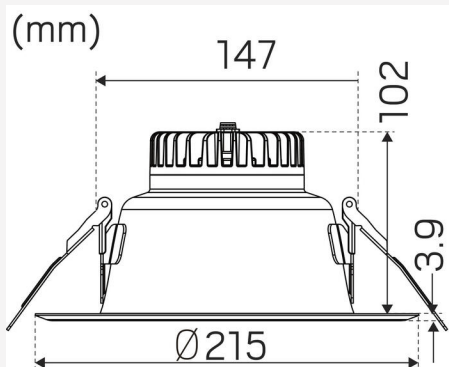

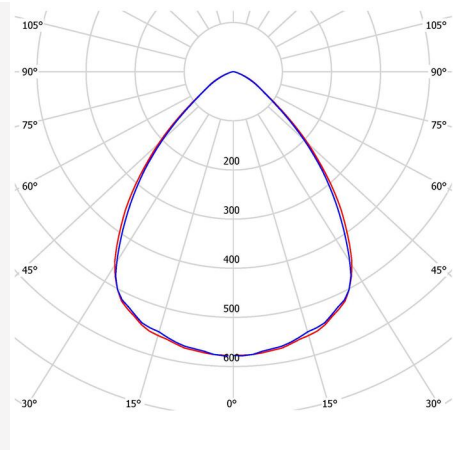

**hide a lite**  
choice

We focus on sustainability using recycled material for creating innovative luminaires, as well as replaceable LEDs and drivers.

Luminaires built for the future!

## Echo M DALI - DIP DIM

mA	Effekt	3000K	4000K	5700K
500mA	21W	1780 lm	1870 lm	1830 lm
450mA	19W	1610 lm	1700 lm	1660 lm
400mA	17W	1470 lm	1550 lm	1500 lm
350mA	15W	1280 lm	1340 lm	1300 lm
300mA	13W	1110 lm	1160 lm	1130 lm
250mA	11W	950 lm	980 lm	960 lm

