



PAVE POST DECO II ANTHRACITE

Stylish post luminaire in the Pave family. Perfect outside a large property or car park that needs a lot of light. Choose the appearance and increase anti-glare for your luminaire in combination with Top, Deco II and Deco IV. Post bracket for 60mm posts. Replaceable LED and driver. Selectable lumen output and adjustable colour temperature via DIP-switch. 10kV surge voltage protection as standard. Adapter available as accessory for fitting on 48mm post. Comes with 5m of pre-mounted rubber cable for easy connection.

DESCRIPTION

GTIN:	7392971147215
Item Name:	Pave Post Deco II Anthracite
Warranty:	5 years

LIGHT TECHNICAL DATA

Max. Luminaire Lumen (lm):	2580
Light Source:	LED
Light Source Included:	Yes
Replaceability:	Replaceable LED by professional, Replaceable Control gear by professional
LED Colour:	White
Colour Temperature (K):	3000, 4000
Colour Rendering Index (Ra):	>80
Colour Consistency (SDCM):	3
Luminous Intensity (cd):	645
Beam Angle (°):	180
Light sharing:	Symmetric
Light Outlet:	Direct
Number of Lamps (pcs):	1
Number of LED (pcs):	144
Life Time:	h Ta °C
Nominal Life Time (h):	100000
Lumen maintenance 50 000h:	L88
Lumen maintenance 75 000h:	L83
Lumen maintenance 100 000h:	L80
LLMF @ 50 000h:	0.88
LLMF @ 100 000h:	0.8
Life Time Driver:	100 000h/20%
Flicker (PstLM):	0
Stroboscopic effect (SVM):	0

TECHNICAL DATA

Voltage (type):	AC
Voltage Interval (V):	220...240V
Voltage Nominal (V):	230
Line Frequency (Hz):	50, 60
Power LED (W):	25,9
Max. Power Luminaire (W):	30
Max. System Power (W):	30
Max. Efficiency Luminaire (lm/W):	86
Max. Efficiency System (lm/W):	86

Containing light source energy efficiency class (EU) 2019/2015: C

OPERATION AND CONNECTION

Dimmable:	No
Type of Dimming:	DIP-Switch Power
Driver Included:	Yes - replaceable
Driver Model:	Constant Current
Driver Manufacturer:	Hide-a-lite
Connection (type):	Quick Terminal
Length Connection (cm):	500
Connection (mm2):	3x0,75-2,5
Strain Relief:	Yes
Power Factor λ :	0,9
Power loss (W):	5,1
Leakage current (mA) (at 230 V, 50 Hz, full load):	0,29
THD (%):	20
Constant Current (mA):	450, 650, 800, 1000
Min. Ta (°C):	-30
Max. Ta (°C):	40
Max. Tc (°C):	88
Protection Against:	Short Circuit, Overheating 130°C
Inrush current (max/time):	15A 500 μ s
Mains surge protection DM (kV):	10
Mains surge protection CM (kV):	10
Fuse B10 (pcs):	22
Fuse B16 (pcs):	35
Fuse C10 (pcs):	36
Fuse C16 (pcs):	58

COLOR AND MATERIAL

Material:	Aluminium, Polycarbonate
Color:	Antracit
Environmental Assessment:	Byggvarubedömningen
Available in special color:	Yes

MEASUREMENT AND INSTALLATION

Operating Environment:	Indoor / dry locations, Outdoor
IP Degree of Protection:	65
Protection Class:	I
Installation:	Post assembly
Mounting Installation:	Screw Mounting
Approval Marks:	CE, a Hide-a-lite Choice
Impact Strength:	IK10
Filament Test IEC 695-2-1(°C):	650
Height (mm):	466
Diameter (mm):	350
Weight (kg):	4,47

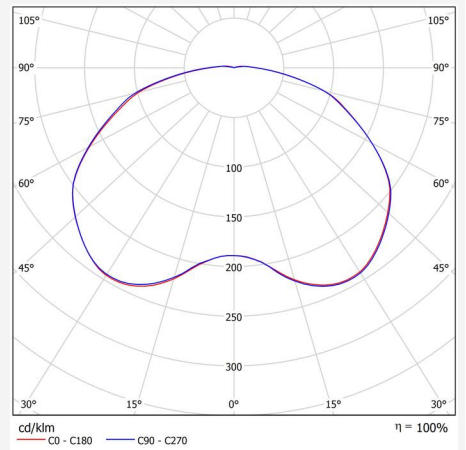
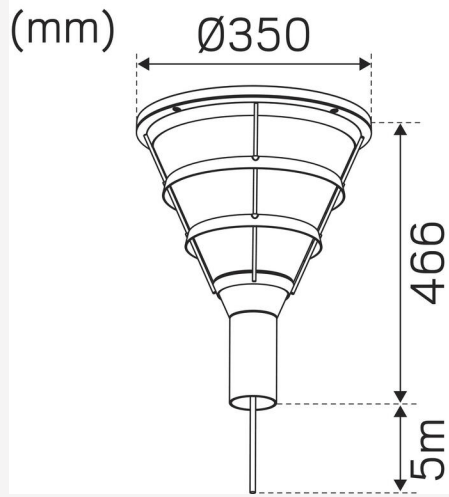

hide a lite
choice

We focus on sustainability using recycled material for creating innovative luminaires, as well as replaceable LEDs and drivers.

Luminaires built for the future!

DIP SWITCH POWER

Factory setting: 3000K 20W		Pave Post Pave Post Top		Pave Post Deco II Pave Post Top Deco II		Pave Post Deco IV Pave Post Top Deco IV	
mA	Watt	3000K	4000K	3000K	4000K	3000K	4000K
450mA	15W	1320lm	1450lm	1110lm	1230lm	830lm	920lm
650mA	20W	1610lm	1970lm	1580lm	1740lm	1180lm	1310lm
800mA	25W	2200lm	2380lm	1900lm	2100lm	1430lm	1580lm
1000mA	30W	2690lm	3030lm	2350lm	2580lm	1760lm	1940lm

